

### 102BS

Double Ended Beam

IP68

STAINLESS STEEL  
WELDED SEAL

Options:

- FM, ATEX, IECEx Approved



### 102BSM5

Compression Weigh Module

Features:

- Self-checking with integrated uplift protection
- Top Plate bolts directly to tank leg





### Complete Kit Includes

- ✓ 102BSM5 Mounts
- ✓ 102BS Load Cells
- ✓ Junction Box (Signal or Exc)
- ✓ Load Cell Cable

Part Number / Capacity	J-Box	Cable
<b>3 Module Kit</b>	*J-Box (specify model when ordering)	
MK3-102BSM5- <b>50Klb</b>	<b>J04SA-16</b>	1 roll (65ft/20m)
MK3-102BSM5- <b>60Klb</b>		
MK3-102BSM5- <b>75Klb</b>		
<b>4 Module Kit</b>	*J-Box (specify model when ordering)	
MK4-102BSM5- <b>50Klb</b>	<b>J04SA-16</b>	1 roll (65ft/20m)
MK4-102BSM5- <b>60Klb</b>		
MK4-102BSM5- <b>75Klb</b>		

**MK4 J-Box:** Signal or Excitation / Aluminum, Stainless Steel or Fiberglass Enclosure

### Features

- Capacities (per module) 50Klb-75Klb
- Top Plate bolts directly to tank leg; no need for additional hardware

### Applications

- Heavy-Capacity, Silo, Hopper Weighing
- Chemical & Agricultural Facilities
- Batching & Inventory Management for Storage Vessels

### Drawings

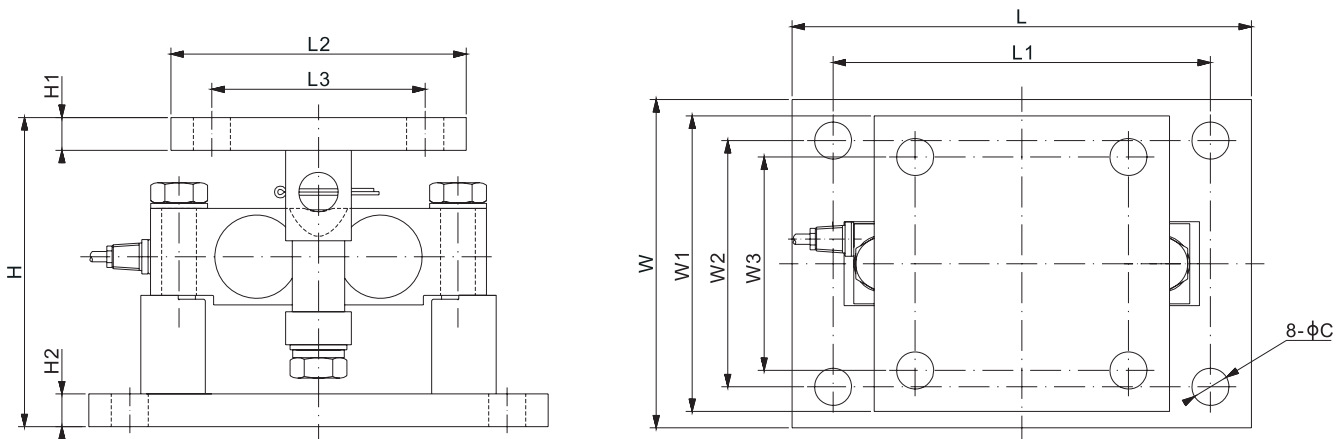

### Dimensions (inches)

Capacity	C	H	H1	H2	L	L1	L2	L3	W	W1	W2	W3
50-75Klb	1.13	9.42	1.00	1.00	14.00	11.50	9.00	6.50	10.00	9.00	7.50	6.50