



Features:

- Assembles: 101NH S-beam load cell
- Capacities: 50lb-10Klb
- Allows for high accuracy tension loading

Load Cell Certifications:



Load Cell Not Included.

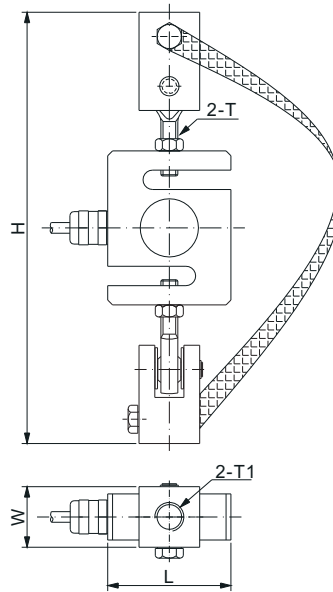

DIMENSIONS

LOAD CELL CAPACITY	H _{Min/Max}	W	L	T	T1
lb/inches					
50-250	6.69/7.09	0.99	2.00	1/4-28 UNF-2A	1/2-13 UNC-2B
500-2,000	9.57/9.88	1.58	2.00	1/2-20 UNF-2A	3/4-10 UNC-2B
5,000	12.13/12.60	2.16	3.00	3/4-16 UNF-2A	3/4-10 UNC-2B
10,000	17.17/18.07	3.15	3.15	3/4-16 UNF-2A	1-8 UNC-2B
kg/mm (conversion of above dimensions)					
22.7-136.1	170/180	25.0	50.8	1/4-28 UNF-2A	1/2-13 UNC-2B
226.8-907.2	243/251	40.0	50.8	1/2-20 UNF-2A	3/4-10 UNC-2B
2,268	308/320	55.0	76.2	3/4-16 UNF-2A	3/4-10 UNC-2B
4,536	436/459	80.0	80.0	3/4-16 UNF-2A	1-8 UNC-2B

PART NUMBER

Load Cell Capacity	Part No.	Weight (kg) Approx.
50lb-250lb.....	101NHM2-(50-250)lb	0.4
500lb-2Klb	101NHM2-(0.5-2)Klb.....	1.4
5Klb.....	101NHM2-5Klb.....	3.2
10Klb.....	101NHM2-E-10Klb.....	8.5